

# Industrial Baymaster™ LED Luminaire

## High Bay for Ordinary Locations

**NEC/CEC:**  
**Marine outside type (salt water) for USA Only**  
**Wet locations**  
**Type 3R, 4, 4X**  
**IP66/67**

### Applications

- Powerful, efficient weatherproof lighting for applications such as:
  - Warehouses
  - Waste water treatment facilities
  - Production facilities
  - Processing plants
  - Storage areas
- Locations requiring IP66/67, Type 4X, marine and wet location.
- Locations requiring dependable, consistent lighting in extreme hot/cold temperature environments.

### Features

- Three lumen outputs provide up to 19,500 lumens.

Nominal Lumens ①	Wattage (W)	Efficacy (lpw)	HID Equivalent	Model Number
9,500	70	136	175W-250W	IBLL6/IBLLPL6
15,000	110	136	250W-400W	IBLL7/IBLLPL7
19,500	150	130	400W-750W	IBLL8/IBLLPL8

① Nominal lumen value for 5000K, detailed lumen information provided in tables.

- Choice of optics for optimal light distribution in a variety of applications.
- Unique quick mount pendant system allows for easy prewiring without supporting the High Bay in place. Quick mount adapter hood includes one 3/4" NPT entry.
- Alternate mounting system allows for "Y" cable mount and easy wiring via a separate field wiring compartment with a screw terminal block (can accept UL/CSA 26-10AWG).
- Two 3/4" NPT entries provided. (Two close up plugs provided when quick mount pendant system is ordered).
- One 1/2" NPT close up plug provided on quickmount model for use with accessory drain assembly.
- Choice of color temperature (CCT); 5000K cool white or 3000K warm white.
- Rugged and compact housing with superior thermal design translates to long luminaire life.
- Ambient Temperature: -40 °C to +65 °C (-40 °F to +149 °F)
- Heavy duty, high temperature silicone rubber gaskets.
- Thermal shock and impact resistant clear or frosted glass lens.
- Choice of Input Voltages:
  - 120-277 Vac 50/60 Hz, 170-300 Vdc
  - 347-480 Vac 50/60 Hz
- Standard 6kV surge protection.
- Captive fasteners secure one piece lens.
- Field replaceable LED driver and lens cover.

### Options

- Improved safety cable design with multiple retention points, purchase separately
- Guard available, purchase separately
- 10kV Surge Protection
- Y mount cable assembly, purchase separately
- Drain assembly, purchase separately

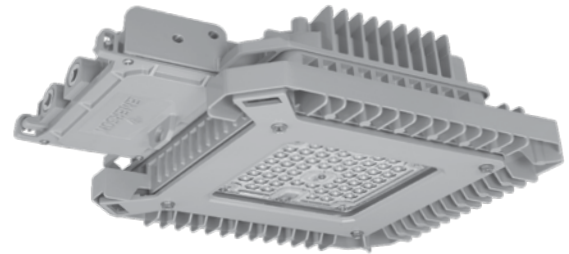

High Bay

### Standard Materials

- Housing and lens door: copperfree (4/10 of 1% max.) aluminum
- Gaskets: silicone rubber
- Quick mount hood and body: copperfree (4/10 of 1% max.) aluminum
- Exterior hardware: stainless steel
- Close up plugs: (two 3/4", one 1/2") aluminum provided for quick mount, (one 3/4") aluminum provided otherwise
- Guard and safety cable: stainless steel

### Standard Finishes

- Housing, lens cover, quick mount body and hood; baked gray epoxy powder coat finish, electrostatically applied for complete uniform protection

### Related Products

- See Industrial Baymaster™ HL LED for locations requiring higher lumen outputs of 24K, 30K and 38K
- See Baymaster™ LED for Class I, Division 2 hazardous locations requiring lumen outputs of 9.5K, 15K and 19.5K
- See Baymaster™ HL LED for Class I, Division 2 hazardous locations requiring higher lumen outputs of 24K, 30K and 38K

LED/HIGH BAY: NEC/CEC ORDINARY LOCATION

Appleton®

# Industrial Baymaster™ LED Luminaire

## High Bay for Ordinary Locations

NEC/CEC:  
 Marine outside type (salt water) for USA Only  
 Wet locations  
 Type 3R, 4, 4X  
 IP66/67

### Illustrated Features

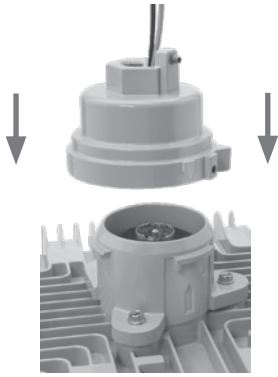

#### Quick Mount Pendant System

Appleton's patented quick mount pendant system allows for easy prewiring of a hood for quick, one person fixture installation. Simply align the arrows, push up, and rotate the luminaire a quarter turn until it locks into place. Specify quick mount pendant with a "P" in the fifth digit of the part number.



#### Cable Mount Option

The Baymaster High Bay can also be mounted with two Y style aircraft cables with spring clips, secured to eye bolts on the luminaire housing. Non quick mount models can be cable mounted and are wired through the 3/4" NPT entries in the wire box.



#### Driver Assembly

Replaceable drivers are waterproof (IP67) and offer standard 6kV surge protection and over temperature protection.

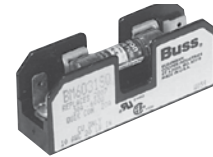

#### Optional Fusing \*

Luminaire can be ordered with optional fusing. Fusing is not field installable.  
 \* Use of fuse voids marine rating.

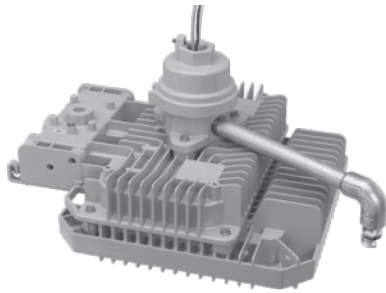

#### Optional Drain Assembly

Includes 9" long, 1/2" trade size conduit nipple, elbow and drain.



#### Replaceable Cover Assembly

The replaceable cover assembly is available with clear or frosted glass.

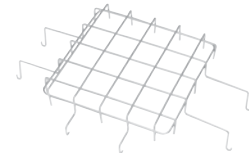

#### Optional Wire Guard

Stainless steel wire guard can be used for additional protection.

LED/HIGH BAY- NEC/CEC ORDINARY LOCATION

Appleton®

# Industrial Baymaster™ LED Luminaire

## High Bay for Ordinary Locations

**NEC/CEC:**  
 Marine outside type (salt water) for USA Only  
 Wet locations  
 Type 3R, 4, 4X  
 IP66/67

### NEC/CEC Certifications and Compliances

- UL Standards:
  - UL1598, Luminaires
  - UL1598A, Luminaires for Installation on Marine Vessels
  - UL 8750, LED Equipment for Use in Lighting Products
- CSA Standards:
  - CSA C22.2 No. 250.0, Luminaires
- cCSAus: 164460, Certificate Number: 70073607

### DesignLights™ Consortium (for the following models)

- All models pending.

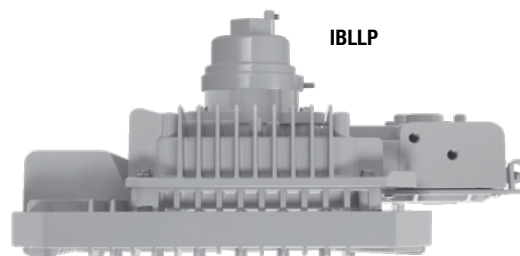
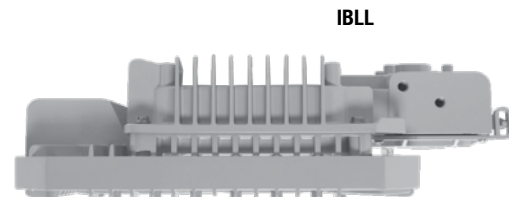

Order using catalog numbering guides below or select catalog number from tables on following pages.

<b>IBLL</b>	<b>P</b>	<b>L7</b>	<b>C</b>	<b>G</b>	<b>M</b>	<b>N</b>	<b>BU</b>	<b>S</b>
Series: IBLL: Baymaster LED Series	Mounting: P - Quick Mount Pendant Blank - No Quick Mount	Lumen Level: L6 - 9K L7 - 15K L8 - 19K	Color Temp CCT: C - 5000K W - 3000K ②	Diffusion: G - Clear Glass F - Frosted Glass ③	M - Medium W - Wide A - Aisle	N - None	Voltage: BU = 120V-277Vac 50/60 Hz, 170-300Vdc BH = 347-480Vac 50/60 Hz	F - Fusing ④ S - 10kV Surge Protection

### Lumen Output Tables ⑤:

Lumen Output for Clear Glass Lens			
	IBLL6/IBLLP6	IBLL7/IBLLP7	IBLL8/IBLLP8
Type V Medium (Non Optic), 5000K CCT, CRI 70	9800	15400	20100
Type V Wide 3000K CCT, CRI 80	7500	11400	14700
Type V Wide 5000K CCT, CRI 70	8700	13600	17700
Type V Aisle 3000K CCT, CRI 80	8400	12600	16400
Type V Aisle 5000K CCT, CRI 70	9700	15200	19800

Lumen Output for Frosted Glass Lens			
	IBLL6/IBLLP6	IBLL7/IBLLP7	IBLL8/IBLLP8
Type V (Non Optic), 5000K CCT, CRI 70	8200	13000	16700

① Quick mount pendant includes pre wired, factory installed, quick mount pendant body and hood. No quick mount models are wired through the 3/4" NPT entries and a provided screw terminal block in the wiring compartment.

② 3000K CCT (Warm) is only available with Type V Wide or Aisle light patterns

③ Frosted Glass is only available with Type V Medium light pattern

④ Use of fuse voids Marine rating.

⑤ All lumen values are typical (tolerance +/-10%).

LED/HIGH BAY: NEC/CEC ORDINARY LOCATION



# Industrial Baymaster™ LED Luminaire

## High Bay for Ordinary Locations

**NEC/CEC:**

Marine outside type (salt water) for USA Only

Wet locations

Type 3R, 4, 4X

IP66/67

**Electrical Ratings** ①

Model Number	Voltage Suffix	Voltage (V)	Input Power (Watts)	Input Current (Amps)	Power Factor (PF)	Total Harmonic Distortion (THD)
<b>IBLL6</b> <b>IBLLPL6</b>	BU	120 Vac	73	0.62	>.9	<20%
		277 Vac	71	0.27		
		170 Vdc	69	0.41	N/A	N/A
		300 Vdc	68	0.23		
BH	347 Vac	71	0.21	>.9	<20%	
	480 Vac	71	0.16			
<b>IBLL7</b> <b>IBLLPL7</b>	BU	120 Vac	111	0.94	>.9	<20%
		277 Vac	106	0.43		
		170 Vdc	113	0.67	N/A	N/A
		300 Vdc	111	0.37		
BH	347 Vac	115	0.33	>.9	<20%	
	480 Vac	115	0.25			
<b>IBLL8</b> <b>IBLLPL8</b>	BU	120 Vac	154	1.30	>.9	<20%
		277 Vac	146	0.56		
		170 Vdc	156	0.92	N/A	N/A
		300 Vdc	152	0.51		
BH	347 Vac	150	0.43	>.9	<20%	
	480 Vac	149	0.32			

LED/HIGH BAY- NEC/CEC ORDINARY LOCATION



Surge Protection: Integral 6KV surge protection. Option for up to 10KV surge protection. (cCSAus only).

① All ratings are typical.

# Industrial Baymaster™ LED Luminaire

## High Bay for Ordinary Locations

NEC/CEC:  
 Marine outside type (salt water) for USA Only  
 Wet locations  
 Type 3R, 4, 4X  
 IP66/67

CCT	Lumen Output	Wattage	Efficacy (lm/W)	Optical Pattern	Catalog Number ①
<b>Clear Glass With Quick Mount Pendant System</b>					
<b>120-277 Vac/170-300 Vdc</b>					
5000K (cool white)	9800	70	140	Type V Medium (120° beam angle)	IBLLPL6CGMNBU
5000K (cool white)	8700	70	124	Type V Wide (140° beam angle)	IBLLPL6CGWNB
5000K (cool white)	9700	70	139	Type I (Aisle)	IBLLPL6CGANBU
3000K (warm white)	7500	70	107	Type V Wide (140° beam angle)	IBLLPL6WGWNB
3000K (warm white)	8400	70	120	Type I (Aisle)	IBLLPL6WGANBU
5000K (cool white)	15400	111	139	Type V Medium (120° beam angle)	IBLLPL7CGMNBU
5000K (cool white)	13600	111	123	Type V Wide (140° beam angle)	IBLLPL7CGWNB
5000K (cool white)	15200	111	137	Type I (Aisle)	IBLLPL7CGANBU
3000K (warm white)	11400	111	103	Type V Wide (140° beam angle)	IBLLPL7WGWNB
3000K (warm white)	12600	111	114	Type I (Aisle)	IBLLPL7WGANBU
5000K (cool white)	20100	155	130	Type V Medium (120° beam angle)	IBLLPL8CGMNBU
5000K (cool white)	17700	155	114	Type V Wide (140° beam angle)	IBLLPL8CGWNB
5000K (cool white)	19800	155	128	Type I (Aisle)	IBLLPL8CGANBU
3000K (warm white)	14700	155	95	Type V Wide (140° beam angle)	IBLLPL8WGWNB
3000K (warm white)	16400	155	106	Type I (Aisle)	IBLLPL8WGANBU
<b>347-480 Vac</b>					
5000K (cool white)	9800	70	140	Type V Medium (120° beam angle)	IBLLPL6CGMNBH
5000K (cool white)	8700	70	124	Type V Wide (140° beam angle)	IBLLPL6CGWNBH
5000K (cool white)	9700	70	139	Type I (Aisle)	IBLLPL6CGANBH
3000K (warm white)	7500	70	107	Type V Wide (140° beam angle)	IBLLPL6WGWNBH
3000K (warm white)	8400	70	120	Type I (Aisle)	IBLLPL6WGANBH
5000K (cool white)	15400	111	139	Type V Medium (120° beam angle)	IBLLPL7CGMNBH
5000K (cool white)	13600	111	123	Type V Wide (140° beam angle)	IBLLPL7CGWNBH
5000K (cool white)	15200	111	137	Type I (Aisle)	IBLLPL7CGANBH
3000K (warm white)	11400	111	103	Type V Wide (140° beam angle)	IBLLPL7WGWNBH
3000K (warm white)	12600	111	114	Type I (Aisle)	IBLLPL7WGANBH
5000K (cool white)	20100	155	130	Type V Medium (120° beam angle)	IBLLPL8CGMNBH
5000K (cool white)	17700	155	114	Type V Wide (140° beam angle)	IBLLPL8CGWNBH
5000K (cool white)	19800	155	128	Type I (Aisle)	IBLLPL8CGANBH
3000K (warm white)	14700	155	95	Type V Wide (140° beam angle)	IBLLPL8WGWNBH
3000K (warm white)	16400	155	106	Type I (Aisle)	IBLLPL8WGANBH
<b>Frosted Glass With Quick Mount Pendant System</b>					
<b>120-277 Vac/170-300 Vdc</b>					
5000K (cool white)	8200	70	117	Type V Medium (120° beam angle)	IBLLPL6CFMNBU
5000K (cool white)	13000	111	117	Type V Medium (120° beam angle)	IBLLPL7CFMNBU
5000K (cool white)	16700	158	106	Type V Medium (120° beam angle)	IBLLPL8CFMNBU
<b>347-480 Vac</b>					
5000K (cool white)	8200	71	115	Type V Medium (120° beam angle)	IBLLPL6CFMNBH
5000K (cool white)	13000	115	113	Type V Medium (120° beam angle)	IBLLPL7CFMNBH
5000K (cool white)	16700	157	106	Type V Medium (120° beam angle)	IBLLPL8CFMNBH

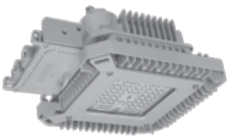

LED/HIGH BAY: NEC/CEC ORDINARY LOCATION



① For Fusing option, add suffix **F** to end of part number, example IBLLPL6CGANBUF.  
 For 10KV surge protection, add suffix **S** to end of part number, example IBLLPL7CGMNBUS.  
 For both Fusing and 10KV surge, add suffix **FS** to end of part number, example IBLLPL8WGANBUFS.

# Industrial Baymaster™ LED Luminaire

## High Bay for Ordinary Locations

**NEC/CEC:**

Marine outside type (salt water) for USA Only

Wet locations

Type 3R, 4, 4X

IP66/67

CCT	Lumen Output	Wattage	Efficacy (lm/W)	Optical Pattern	Catalog Number ①
<b>Clear Glass Without Quick Mount Pendant System</b>					
<b>120-277 Vac/170-300 Vdc</b>					
5000K (cool white)	9800	70	140	Type V Medium (120° beam angle)	IBLL6CGMNBU
5000K (cool white)	8700	70	124	Type V Wide (140° beam angle)	IBLL6CGWNB
5000K (cool white)	9700	70	139	Type I (Aisle)	IBLL6CGANBU
3000K (warm white)	7500	70	107	Type V Wide (140° beam angle)	IBLL6WGNBU
3000K (warm white)	8400	70	120	Type I (Aisle)	IBLL6WGANBU
5000K (cool white)	15400	111	139	Type V Medium (120° beam angle)	IBLL7CGMNBU
5000K (cool white)	13600	111	123	Type V Wide (140° beam angle)	IBLL7CGWNB
5000K (cool white)	15200	111	137	Type I (Aisle)	IBLL7CGANBU
3000K (warm white)	11400	111	103	Type V Wide (140° beam angle)	IBLL7WGNBU
3000K (warm white)	12600	111	114	Type I (Aisle)	IBLL7WGANBU
5000K (cool white)	20100	155	130	Type V Medium (120° beam angle)	IBLL8CGMNBU
5000K (cool white)	17700	155	114	Type V Wide (140° beam angle)	IBLL8CGWNB
5000K (cool white)	19800	155	128	Type I (Aisle)	IBLL8CGANBU
3000K (warm white)	14700	155	95	Type V Wide (140° beam angle)	IBLL8WGNBU
3000K (warm white)	16400	155	106	Type I (Aisle)	IBLL8WGANBU
<b>347-480 Vac</b>					
5000K (cool white)	9800	70	140	Type V Medium (120° beam angle)	IBLL6CGMNBH
5000K (cool white)	8700	70	124	Type V Wide (140° beam angle)	IBLL6CGWNBH
5000K (cool white)	9700	70	139	Type I (Aisle)	IBLL6CGANBH
3000K (warm white)	7500	70	107	Type V Wide (140° beam angle)	IBLL6WGNBH
3000K (warm white)	8400	70	120	Type I (Aisle)	IBLL6WGANBH
5000K (cool white)	15400	111	139	Type V Medium (120° beam angle)	IBLL7CGMNBH
5000K (cool white)	13600	111	123	Type V Wide (140° beam angle)	IBLL7CGWNBH
5000K (cool white)	15200	111	137	Type I (Aisle)	IBLL7CGANBH
3000K (warm white)	11400	111	103	Type V Wide (140° beam angle)	IBLL7WGNBH
3000K (warm white)	12600	111	114	Type I (Aisle)	IBLL7WGANBH
5000K (cool white)	20100	155	130	Type V Medium (120° beam angle)	IBLL8CGMNBH
5000K (cool white)	17700	155	114	Type V Wide (140° beam angle)	IBLL8CGWNBH
5000K (cool white)	19800	155	128	Type I (Aisle)	IBLL8CGANBH
3000K (warm white)	14700	155	95	Type V Wide (140° beam angle)	IBLL8WGNBH
3000K (warm white)	16400	155	106	Type I (Aisle)	IBLL8WGANBH
<b>Frosted Glass Without Quick Mount Pendant System</b>					
<b>120-277 Vac/170-300 Vdc</b>					
5000K (cool white)	8200	70	117	Type V Medium (120° beam angle)	IBLL6CFMNBU
5000K (cool white)	13000	111	117	Type V Medium (120° beam angle)	IBLL7CFMNBU
5000K (cool white)	16700	158	106	Type V Medium (120° beam angle)	IBLL8CFMNBU
<b>347-480 Vac</b>					
5000K (cool white)	8200	71	115	Type V Medium (120° beam angle)	IBLL6CFMNBH
5000K (cool white)	13000	115	113	Type V Medium (120° beam angle)	IBLL7CFMNBH
5000K (cool white)	16700	157	106	Type V Medium (120° beam angle)	IBLL8CFMNBH

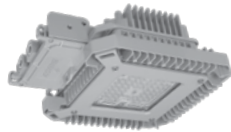
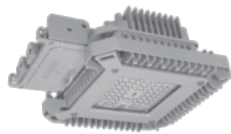

LED/HIGH BAY- NEC/CEC ORDINARY LOCATION

Appleton®





① For Fusing option, add suffix **F** to end of part number, example AMLGL8CG6BUF.  
 For 10KV surge protection, add suffix **S** to end of part number, example AMLGL7CG7BUS.  
 For both Fusing and 10KV surge, add suffix **FS** to end of part number, example AMLGL8CG7BUFS.

# Industrial Baymaster™ LED Luminaire

## High Bay for Ordinary Locations

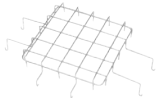
**NEC/CEC:**  
*Marine outside type (salt water) for USA Only*  
**Wet locations**  
 Type 3R, 4, 4X  
 IP66/67

### Accessories and Replacement Parts

	Description	Catalog Number
<b>Wire Guard</b>		
	Stainless steel.	LGGUARD
<b>Safety Cable</b>		
	Stainless steel.	LEDSC
<b>Drain</b>		
	9" long, 1/2" trade size drain assembly for use with quick mount pendant hood.	LEDDR9
<b>Y Mounting Cable</b>		
	1.5 M (5 ft.) cable mount - stainless steel. Includes two (5 ft.) Y cables with spring clips and four eye bolts.	LEDC5
<b>Safety Support Hooks</b>		
	3/4" malleable iron hook and loop	EFHM-75

LED/HIGH BAY: NEC/CEC ORDINARY LOCATION

 **Appleton**

# Industrial Baymaster™ LED Luminaire

## High Bay for Ordinary Locations

**NEC/CEC:**

Marine outside type (salt water) for USA Only

Wet locations

Type 3R, 4, 4X

IP66/67

### Replacement Covers



Clear replacement cover

**BLLCLEAR**

Frosted replacement cover

**BLLFROST**

	Voltage	Driver Wattage	Constant Current Setting	Luminaire Model	CCT	Catalog Number
	BU	100 watt	410mA	IBLL6C/ IBLLPL6C IBLL6W/ IBLLPL6W	5000K and 3000K	<b>APMS100C105UD41</b>
	BH					<b>APMS100C105HD41</b>
	BU	150 watt	650mA	IBLL7W/ IBLLPL7W	3000K	<b>APMS150C105UD65</b>
	BH					<b>APMS150C105HD65</b>
	BU	150 watt	680mA	IBLL7C/ IBLLPL7C	5000K	<b>APMS150C105UD68</b>
	BH					<b>APMS150C105HD68</b>
	BU	150 watt	890mA	IBLL8W/ IBLLPL8W	3000K	<b>APMS150C105UD89</b>
	BH					<b>APMS150C105HD89</b>
BU	150 watt	930mA	IBLL8C/ IBLLPL8C	5000K	<b>APMS150C105HD93</b>	
BH					<b>APMS150C105HD93</b>	

### Industrial Baymaster Accessory Weights

Description	Weight in kg (lbs)
IBLL6/IBLLPL6, IBLL7/IBLLPL7, IBLL8/IBLLPL8 Luminaires	9.8 (21.6)
Quick Mount Hood	0.4 (0.9)
Guard	0.2 (0.4)
Safety Cable	0.2 (0.4)
Drain	0.5 (1.2)
Y Cable Mount	0.5 (1.2)

LED/HIGH BAY- NEC/CEC ORDINARY LOCATION



# Industrial Baymaster™ LED Luminaire

## High Bay for Ordinary Locations

**NEC/CEC:**  
 Marine outside type (salt water) for USA Only  
 Wet locations  
 Type 3R, 4, 4X  
 IP66/67

Dimensions in Millimeters (Inches)

### High Bay – With Quick Mount Pendant System

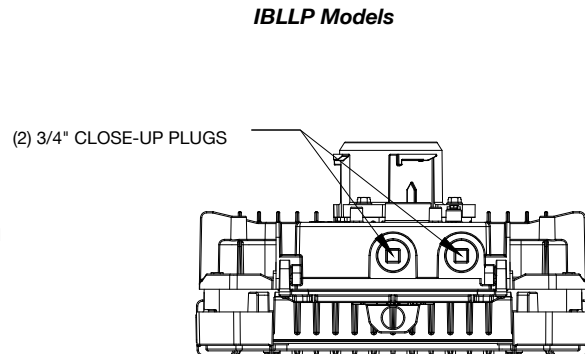
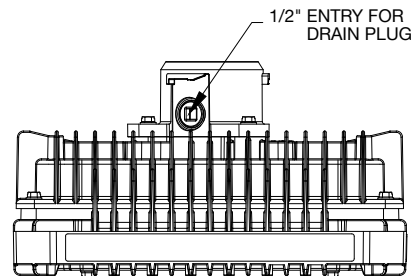
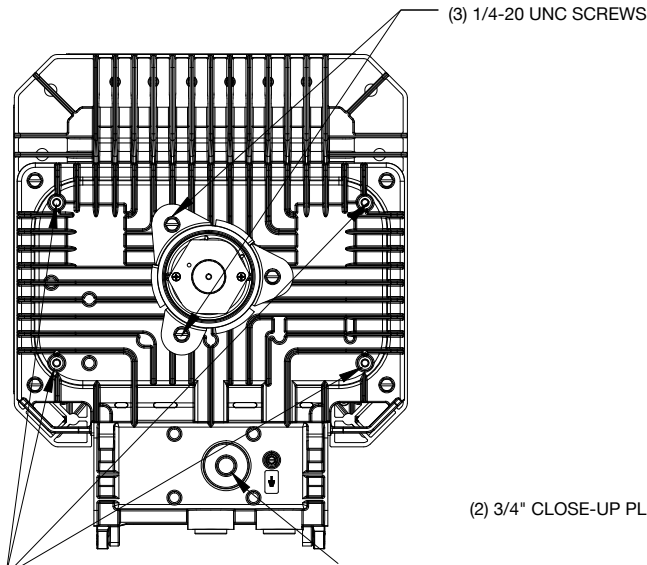
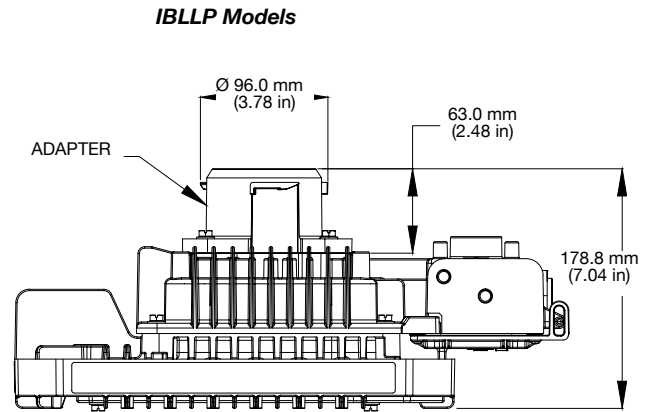
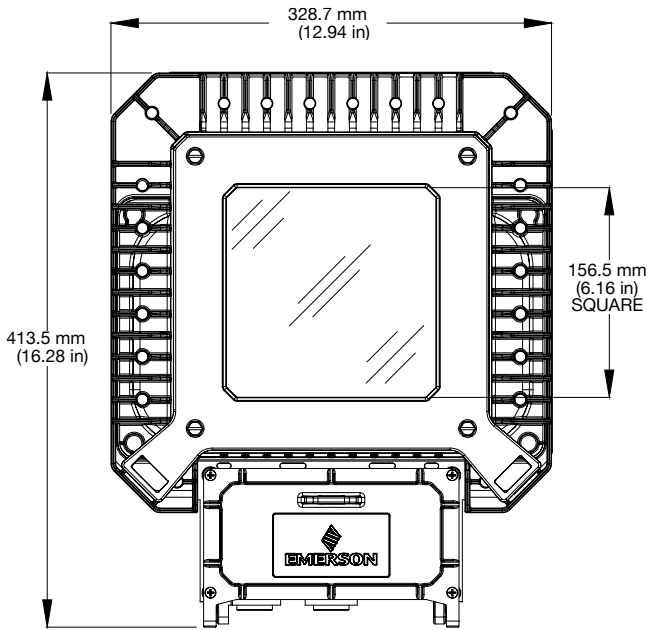

LED/HIGH BAY: NEC/CEC ORDINARY LOCATION



# Industrial Baymaster™ LED Luminaire

## High Bay for Ordinary Locations

NEC/CEC:  
 Marine outside type (salt water) for USA Only  
 Wet locations  
 Type 3R, 4, 4X  
 IP66/67

Dimensions in Millimeters (Inches)

High Bay – No Mount

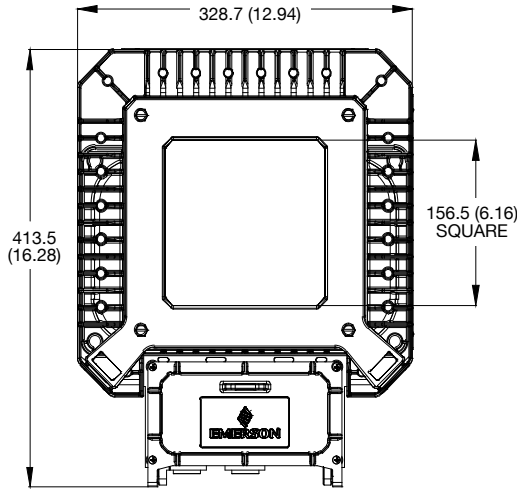

Front View

IBLL Models

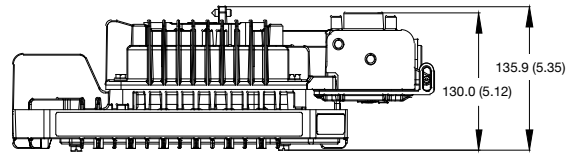

Side View

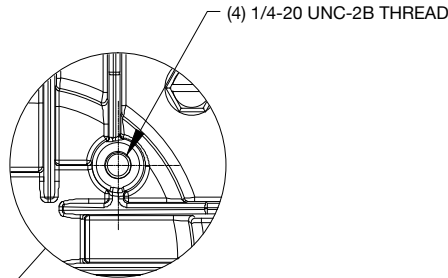
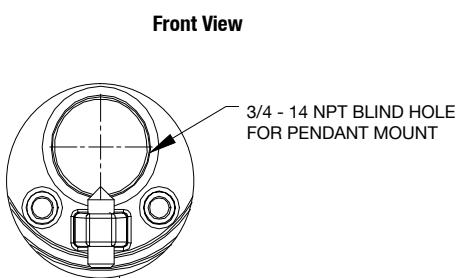

IBLL Models

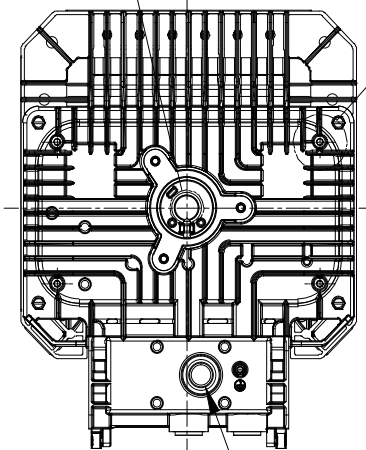

Back View

(1) 3/4 - 14 NPT FOR CABLE ENTRY WITH CLOSE-UP PLUG

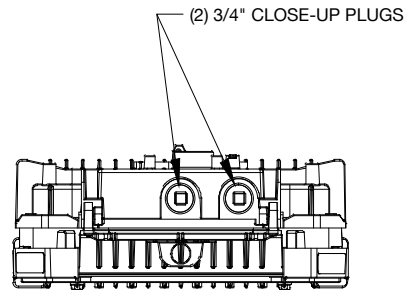

Bottom View

LED/HIGH BAY- NEC/CEC ORDINARY LOCATION

Appleton®

# Industrial Baymaster™ LED Luminaire

## High Bay for Ordinary Locations

**NEC/CEC:**  
 Marine outside type (salt water) for USA Only  
 Wet locations  
 Type 3R, 4, 4X  
 IP66/67

### Photometric Data – DATA SHOWN IS ABSOLUTE

**Aisle, Clear Glass**  
 REPORT NUMBER: **IBLLPL6CGANBU**

Luminaire Lumens 9,679

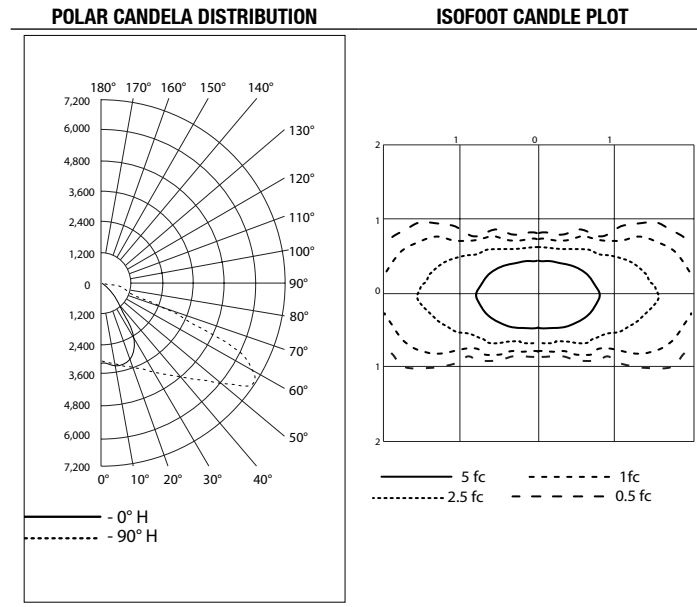

**Aisle, Clear Glass**  
 REPORT NUMBER: **IBLLPL6WGANBU**

Luminaire Lumens 8,432

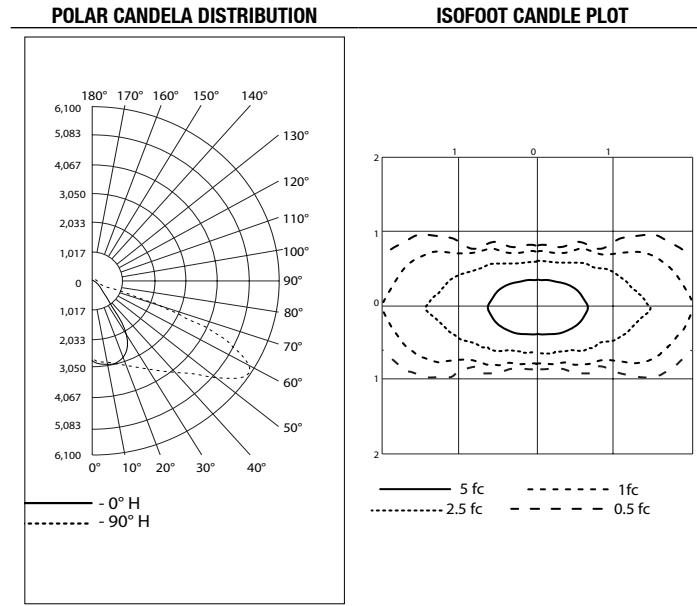

**ZONAL LUMEN SUMMARY**

Zone	Lumens	% Luminaire
0-30	2,820.3	29.1%
0-40	4,676.6	48.3%
0-60	8,307.1	85.8%
60-90	1,371.3	14.2%
70-100	171.1	1.8%
90-120	0	0%
0-90	9,678.4	100%
90-180	0	0%
0-180	9,678.4	100%

**LUMENS PER ZONE**

Zone	Lumens	% Total	Zone
0-10	306.6	3.2%	90-100
10-20	952.6	9.8%	100-110
20-30	1,561.2	16.1%	110-120
30-40	1,856.2	19.2%	120-130
40-50	1,764.9	18.2%	130-140
50-60	1,865.7	19.3%	140-150
60-70	1,200.2	12.4%	150-160
70-80	159.2	1.6%	160-170
80-90	11.9	0.1%	170-180

**ZONAL LUMEN SUMMARY**

Zone	Lumens	% Luminaire
0-30	2,507.0	29.7%
0-40	4,141.6	49.1%
0-60	7,265.0	86.2%
60-90	1,166.5	13.8%
70-100	139.9	1.7%
90-120	0	0%
0-90	8,431.5	100%
90-180	0	0%
0-180	8,431.5	100%

**LUMENS PER ZONE**

Zone	Lumens	% Total	Zone
0-10	275.1	3.3%	90-100
10-20	849.7	10.1%	100-110
20-30	1,382.2	16.4%	110-120
30-40	1,634.5	19.4%	120-130
40-50	1,536.3	18.2%	130-140
50-60	1,587.2	18.8%	140-150
60-70	1,026.6	12.2%	150-160
70-80	128.8	1.5%	160-170
80-90	11.1	0.1%	170-180

LED/HIGH BAY: NEC/CEC ORDINARY LOCATION



# Industrial Baymaster™ LED Luminaire

## High Bay for Ordinary Locations

NEC/CEC:  
 Marine outside type (salt water) for USA Only  
 Wet locations  
 Type 3R, 4, 4X  
 IP66/67

### Photometric Data — DATA SHOWN IS ABSOLUTE

Aisle, Clear Glass

REPORT NUMBER: IBLPL7CGANBU

Luminaire Lumens 15,234

**POLAR CANDELA DISTRIBUTION**

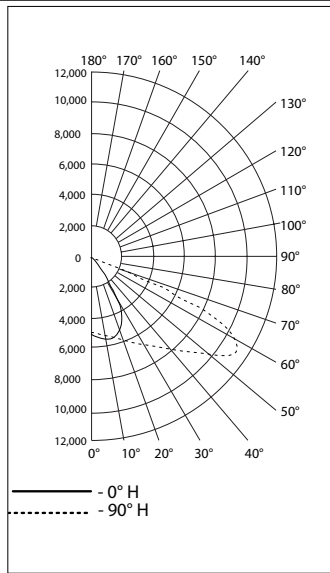

**ISOFOOT CANDLE PLOT**

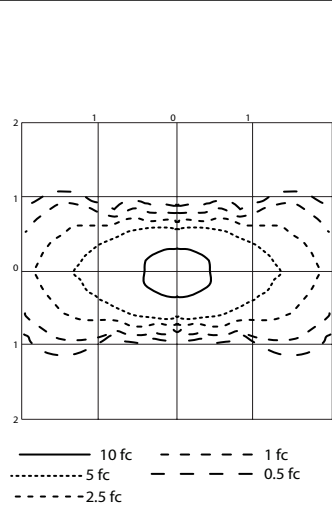

**ZONAL LUMEN SUMMARY**

Zone	Lumens	% Luminaire
0-30	4,456.3	29.3%
0-40	7,383.0	48.5%
0-60	13,097.7	86%
60-90	2,136.1	14%
70-100	262.4	1.7%
90-120	0	0%
0-90	15,233.8	100%
90-180	0	0%
0-180	15,233.8	100%

**LUMENS PER ZONE**

Zone	Lumens	% Total	Zone
0-10	484.8	3.2%	90-100
10-20	1,506.6	9.9%	100-110
20-30	2,464.8	16.2%	110-120
30-40	2,926.7	19.2%	120-130
40-50	2,779.6	18.2%	130-140
50-60	2,935.1	19.3%	140-150
60-70	1,873.7	12.3%	150-160
70-80	243.9	1.6%	160-170
80-90	18.5	0.1%	170-180

Aisle, Clear Glass

REPORT NUMBER: IBLPL7WGANBU

Luminaire Lumens 12,579

**POLAR CANDELA DISTRIBUTION**

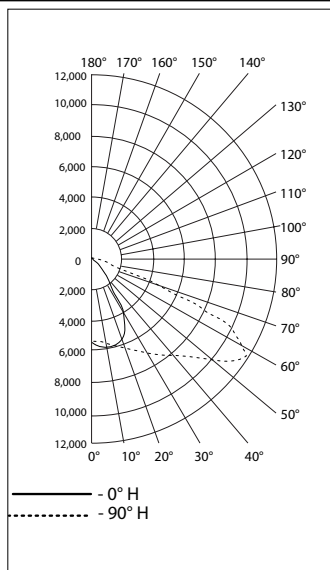

**ISOFOOT CANDLE PLOT**

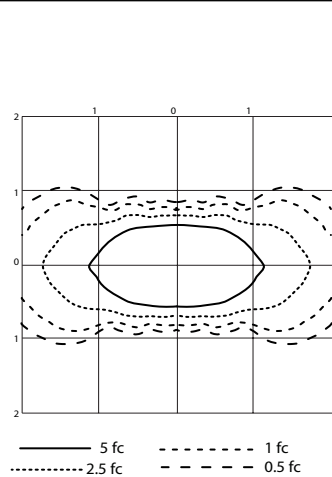

**ZONAL LUMEN SUMMARY**

Zone	Lumens	% Luminaire
0-30	3,750.7	29.8%
0-40	6,191.4	49.2%
0-60	10,866.4	86.4%
60-90	1,711.8	13.6%
70-100	199.6	1.6%
90-120	0	0%
0-90	12,578.2	100%
90-180	0	0%
0-180	12,578.2	100%

**LUMENS PER ZONE**

Zone	Lumens	% Total	Zone
0-10	412.0	3.3%	90-100
10-20	1,272.1	10.1%	100-110
20-30	2,066.7	16.4%	110-120
30-40	2,440.6	19.4%	120-130
40-50	2,296.4	18.3%	130-140
50-60	2,378.7	18.9%	140-150
60-70	1,512.1	12.0%	150-160
70-80	183.7	1.5%	160-170
80-90	15.9	0.1%	170-180

LED/HIGH BAY: NEC/CEC ORDINARY LOCATION



# Industrial Baymaster™ LED Luminaire

## High Bay for Ordinary Locations

NEC/CEC:  
 Marine outside type (salt water) for USA Only  
 Wet locations  
 Type 3R, 4, 4X  
 IP66/67

### Photometric Data – DATA SHOWN IS ABSOLUTE

Aisle, Clear Glass  
 REPORT NUMBER: IBLPL8CGANBU

Luminaire Lumens 19,774

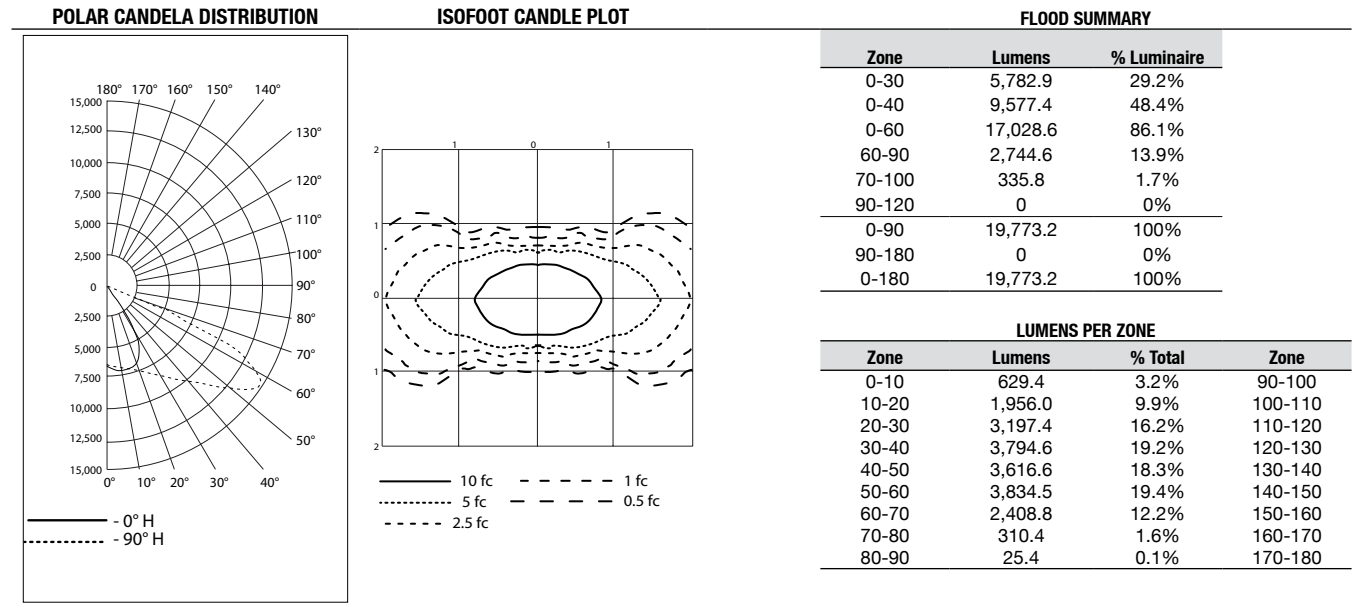

Aisle, Clear Glass  
 REPORT NUMBER: IBLPL8WGANBU

Luminaire Lumens 16,350

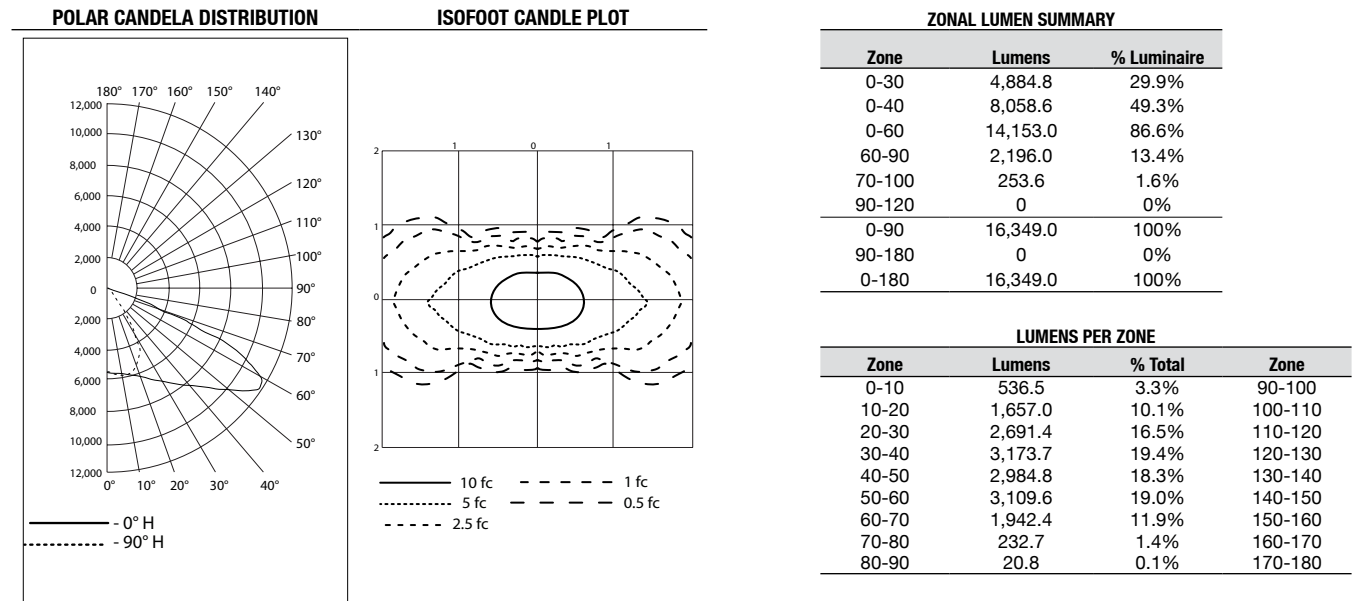

LED/HIGH BAY: NEC/CEC ORDINARY LOCATION



# Industrial Baymaster™ LED Luminaire

## High Bay for Ordinary Locations

NEC/CEC:  
 Marine outside type (salt water) for USA Only  
 Wet locations  
 Type 3R, 4, 4X  
 IP66/67

### Photometric Data — DATA SHOWN IS ABSOLUTE

Type V Wide, Clear Glass

REPORT NUMBER: IBLPL6CGWNBU

Luminaire Lumens 8,682

#### POLAR CANDELA DISTRIBUTION

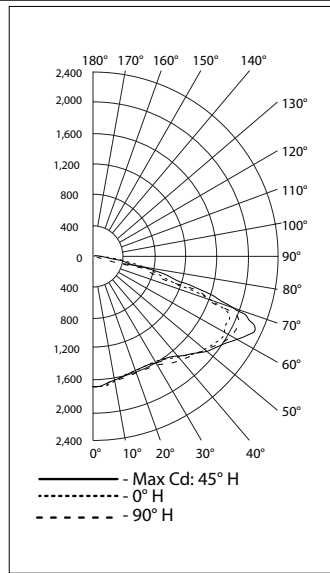

#### ISOFOOT CANDLE PLOT

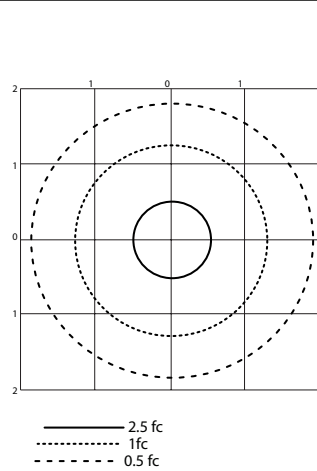

#### FLOOD SUMMARY

Zone	Lumens	% Luminaire
0-30	1,348.9	15.5%
0-40	2,382.8	27.4%
0-60	5,543.9	63.9%
60-90	3,138.6	36.1%
70-100	1,078.8	12.4%
90-120	0	0%
0-90	8,682.5	100%
90-180	0	0%
0-180	8,682.5	100%

#### LUMENS PER ZONE

Zone	Lumens	% Total	Zone
0-10	158.9	1.8%	90-100
10-20	454.7	5.2%	100-110
20-30	735.4	8.5%	110-120
30-40	1,033.9	11.9%	120-130
40-50	1,392.0	16.0%	130-140
50-60	1,769.1	20.4%	140-150
60-70	2,059.8	23.7%	150-160
70-80	1,037.6	11.9%	160-170
80-90	41.3	0.5%	170-180

Type V Wide, Clear Glass

REPORT NUMBER: IBLPI6WGWNBU

Luminaire Lumens 7,506

#### POLAR CANDELA DISTRIBUTION

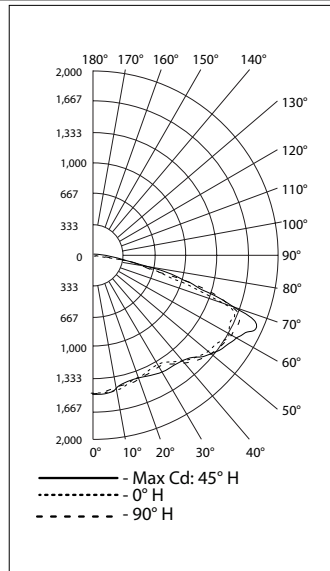

#### ISOFOOT CANDLE PLOT

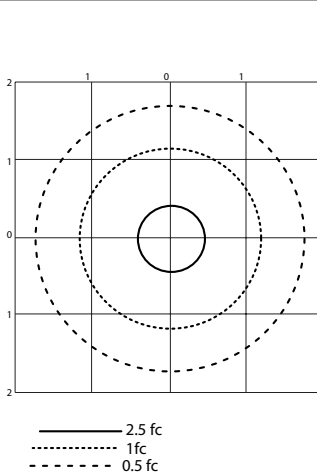

#### FLOOD SUMMARY

Zone	Lumens	% Luminaire
0-30	1,211.6	16.1%
0-40	2,131.1	28.4%
0-60	4,876.2	65%
60-90	2,629.4	35%
70-100	905.2	12.1%
90-120	0	0%
0-90	7,505.6	100%
90-180	0	0%
0-180	7,505.6	100%

#### LUMENS PER ZONE

Zone	Lumens	% Total	Zone
0-10	143.6	1.9%	90-100
10-20	409.1	5.5%	100-110
20-30	658.9	8.8%	110-120
30-40	919.5	12.3%	120-130
40-50	1,224.7	16.3%	130-140
50-60	1,520.4	20.3%	140-150
60-70	1,724.2	23.0%	150-160
70-80	870.4	11.6%	160-170
80-90	34.8	0.5%	170-180

LED/HIGH BAY- NEC/CEC ORDINARY LOCATION



# Industrial Baymaster™ LED Luminaire

## High Bay for Ordinary Locations

NEC/CEC:  
 Marine outside type (salt water) for USA Only  
 Wet locations  
 Type 3R, 4, 4X  
 IP66/67

### Photometric Data — DATA SHOWN IS ABSOLUTE

Type V Wide, Clear Glass

REPORT NUMBER: IBLLPL7CGWNB

Luminaire Lumens 13,608

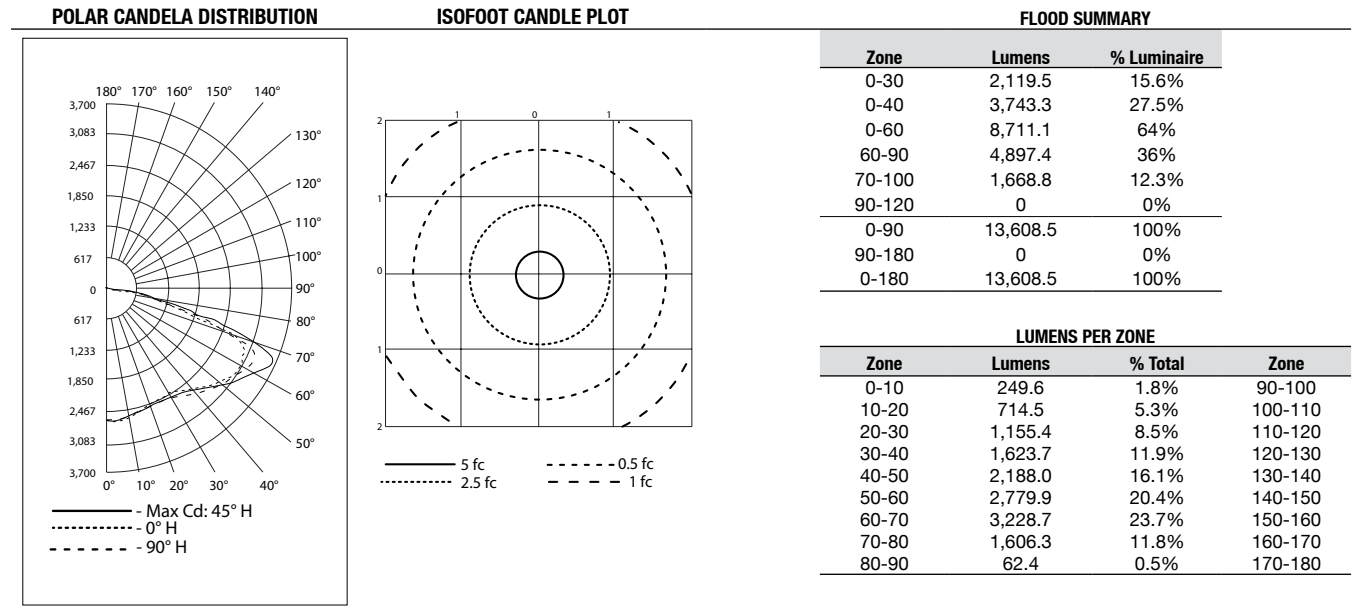

Type V Wide, Clear Glass

REPORT NUMBER: IBLLPI7WGWNB

Luminaire Lumens 11,351

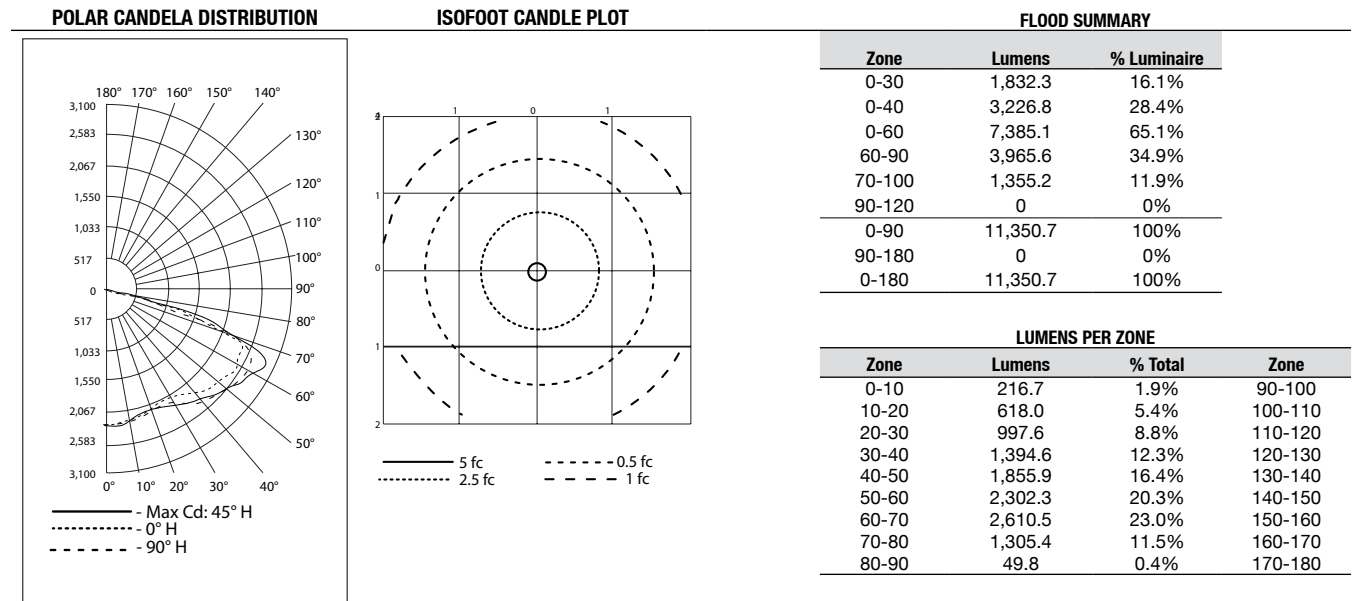

# Industrial Baymaster™ LED Luminaire

## High Bay for Ordinary Locations

NEC/CEC:  
 Marine outside type (salt water) for USA Only  
 Wet locations  
 Type 3R, 4, 4X  
 IP66/67

### Photometric Data — DATA SHOWN IS ABSOLUTE

Type V Wide, Clear Glass

REPORT NUMBER: IBLPL8CGWNBU

Luminaire Lumens 17,710

#### POLAR CANDELA DISTRIBUTION

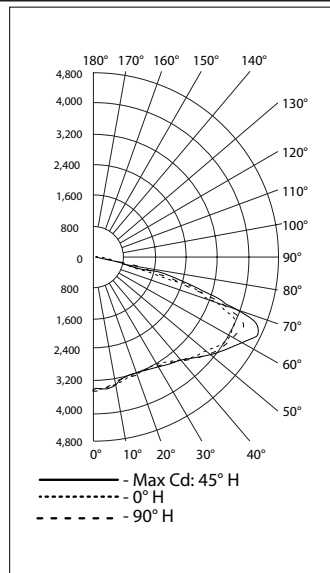

#### ISOFOOT CANDLE PLOT

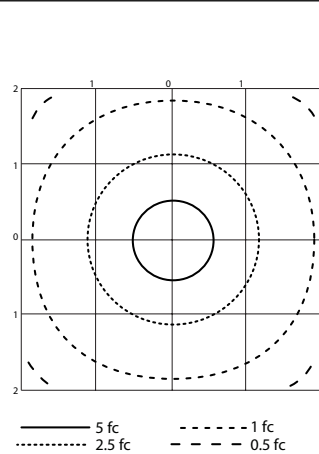

#### FLOOD SUMMARY

Zone	Lumens	% Luminaire
0-30	2,747.6	15.5%
0-40	4,856.1	27.4%
0-60	11,344.9	64.1%
60-90	6,365.5	35.9%
70-100	2,134.3	12.1%
90-120	0	0%
0-90	17,710.3	100%
90-180	0	0%
0-180	17,710.3	100%

#### LUMENS PER ZONE

Zone	Lumens	% Total	Zone
0-10	323.7	1.8%	90-100
10-20	926.5	5.2%	100-110
20-30	1,497.4	8.5%	110-120
30-40	2,108.5	11.9%	120-130
40-50	2,852.1	16.1%	130-140
50-60	3,636.8	20.5%	140-150
60-70	4,231.2	23.9%	150-160
70-80	2,057.9	11.6%	160-170
80-90	76.4	0.4%	170-180

Type V Wide, Clear Glass

REPORT NUMBER: IBLPL8WGWNB

Luminaire Lumens 14,676

#### POLAR CANDELA DISTRIBUTION

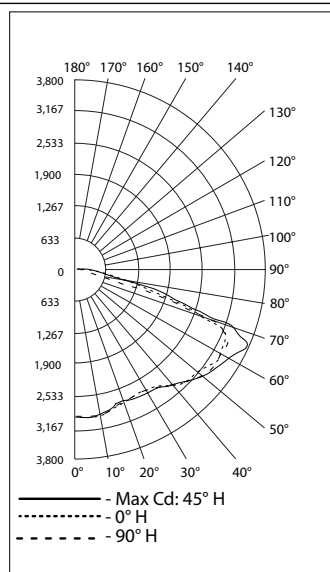

#### ISOFOOT CANDLE PLOT

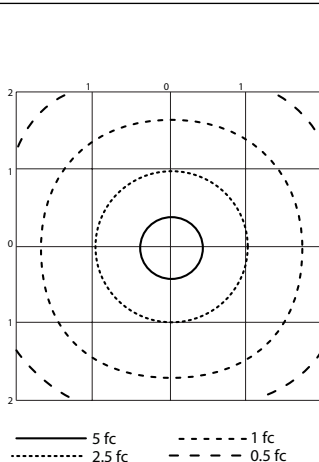

#### FLOOD SUMMARY

Zone	Lumens	% Luminaire
0-30	2,363.9	16.1%
0-40	4,165.7	28.4%
0-60	9,561.5	65.1%
60-90	5,114.9	34.9%
70-100	1,722.7	11.7%
90-120	0	0%
0-90	14,676.4	100%
90-180	0	0%
0-180	14,676.4	100%

#### LUMENS PER ZONE

Zone	Lumens	% Total	Zone
0-10	279.6	1.9%	90-100
10-20	797.4	5.4%	100-110
20-30	1,287.0	8.8%	110-120
30-40	1,801.8	12.3%	120-130
40-50	2,405.1	16.4%	130-140
50-60	2,990.7	20.4%	140-150
60-70	3,392.2	23.1%	150-160
70-80	1,661.4	11.3%	160-170
80-90	61.3	0.4%	170-180

LED/HIGH BAY- NEC/CEC ORDINARY LOCATION



# Industrial Baymaster™ LED Luminaire

## High Bay for Ordinary Locations

**NEC/CEC:**  
 Marine outside type (salt water) for USA Only  
 Wet locations  
 Type 3R, 4, 4X  
 IP66/67

### Photometric Data — DATA SHOWN IS ABSOLUTE

**Type V, Clear Glass**

REPORT NUMBER: IBLLPL6CGMNB

Luminaire Lumens 9,758

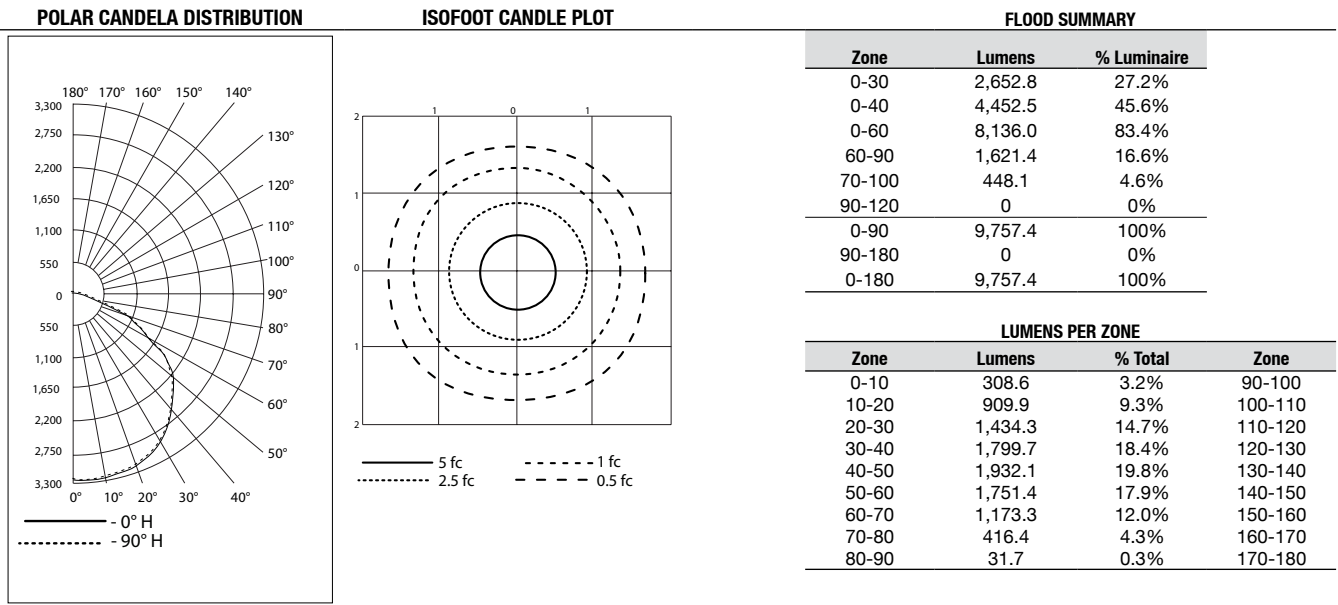

**Type V, Clear Glass**

REPORT NUMBER: IBLLPL7CGMNB

Luminaire Lumens 15,392

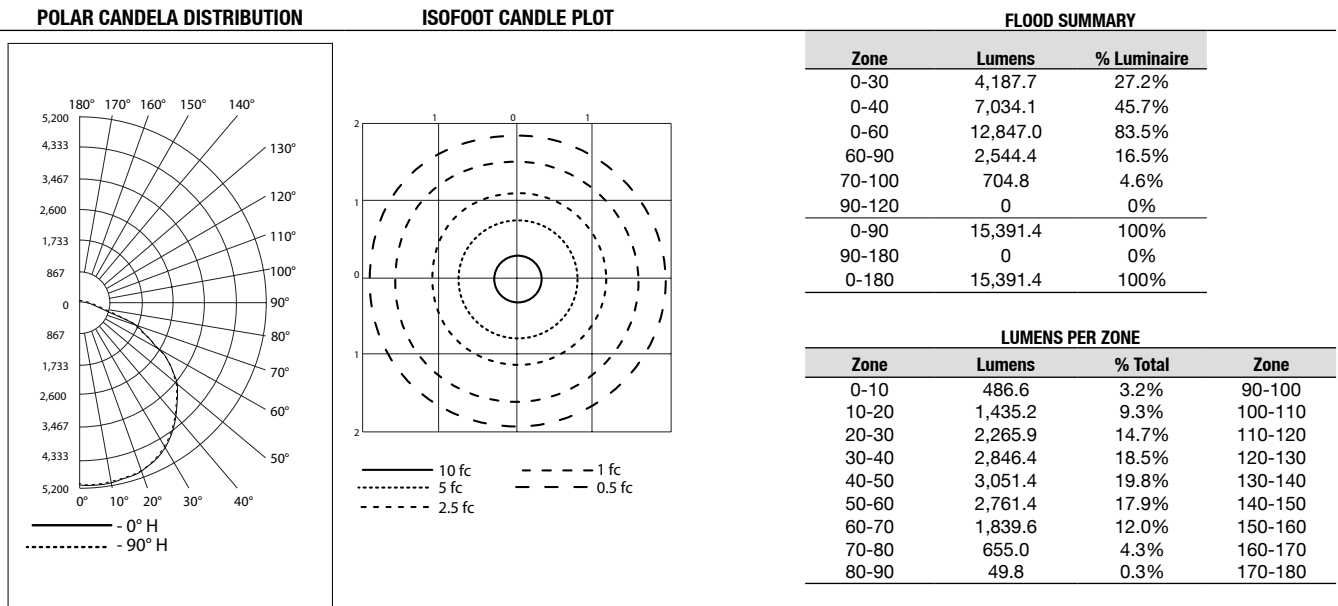

LED/HIGH BAY: NEC/CEC ORDINARY LOCATION



# Industrial Baymaster™ LED Luminaire

## High Bay for Ordinary Locations

**NEC/CEC:**

Marine outside type (salt water) for USA Only

Wet locations

Type 3R, 4, 4X

IP66/67

**Photometric Data – DATA SHOWN IS ABSOLUTE**

**Type V, Clear Glass**

REPORT NUMBER: **IBLLPL8CGMNB**

Luminaire Lumens 20,097

**POLAR CANDELA DISTRIBUTION**

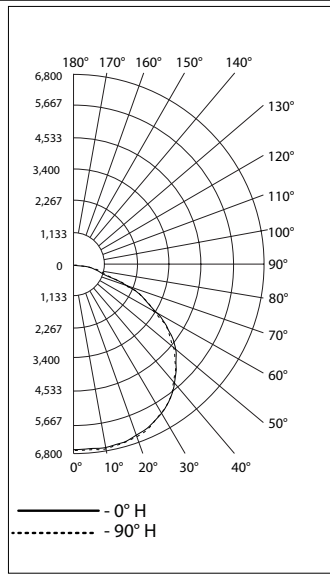

**ISOFOOT CANDLE PLOT**

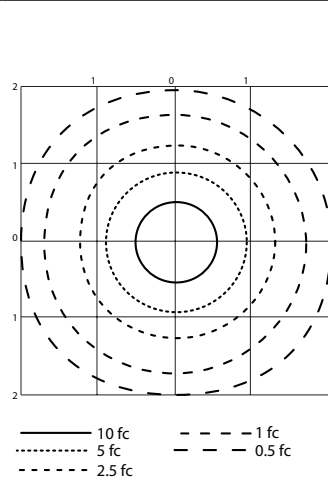

**FLOOD SUMMARY**

Zone	Lumens	% Luminaire
0-30	5,491.5	27.3%
0-40	9,219.3	45.9%
0-60	16,805.9	83.6%
60-90	3,290.0	16.4%
70-100	901.9	4.5%
90-120	0	0%
0-90	20,095.9	100%
90-180	0	0%
0-180	20,095.9	100%

**LUMENS PER ZONE**

Zone	Lumens	% Total	Zone
0-10	638.0	3.2%	90-100
10-20	1,882.3	9.4%	100-110
20-30	2,971.3	14.8%	110-120
30-40	3,727.8	18.6%	120-130
40-50	3,988.4	19.8%	130-140
50-60	3,598.2	17.9%	140-150
60-70	2,388.1	4.2%	150-160
70-80	840.3	11.9%	160-170
80-90	61.7	0.3%	170-180

**Type V, Frosted Glass**

REPORT NUMBER: **IBLLPL6CFMNB**

Luminaire Lumens 8,209

**POLAR CANDELA DISTRIBUTION**

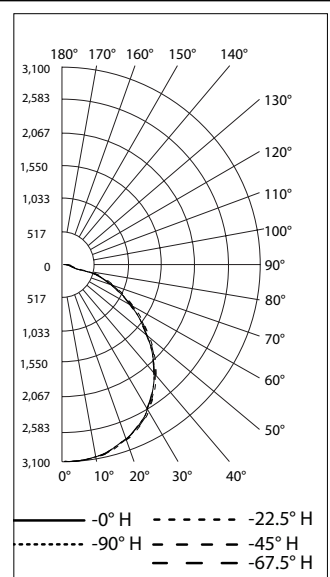

**ISOFOOT CANDLE PLOT**

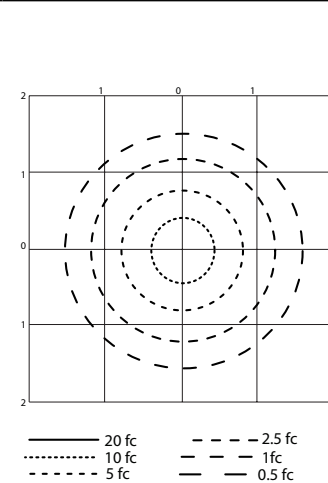

**FLOOD SUMMARY**

Zone	Lumens	% Luminaire
0-30	2,400.5	29.2%
0-40	3,913.4	47.7%
0-60	6,732.3	82%
60-90	1,475.5	18%
70-100	553.0	6.7%
90-120	0	0%
0-90	8,207.9	100%
90-180	0	0%
0-180	8,207.9	100%

**LUMENS PER ZONE**

Zone	Lumens	% Total	Zone
0-10	291.7	3.6%	90-100
10-20	838.5	10.2%	100-110
20-30	1,270.3	15.5%	110-120
30-40	1,512.9	18.4%	120-130
40-50	1,517.4	18.5%	130-140
50-60	1,301.5	15.9%	140-150
60-70	922.5	11.2%	150-160
70-80	468.5	5.7%	160-170
80-90	84.5	1.0%	170-180

LED/HIGH BAY- NEC/CEC ORDINARY LOCATION



# Industrial Baymaster™ LED Luminaire

## High Bay for Ordinary Locations

**NEC/CEC:**  
 Marine outside type (salt water) for USA Only  
 Wet locations  
 Type 3R, 4, 4X  
 IP66/67

### Photometric Data – DATA SHOWN IS ABSOLUTE

**Type V, Frosted Glass**  
 REPORT NUMBER: **IBLLPL7CFMNB**

Luminaire Lumens 12,955

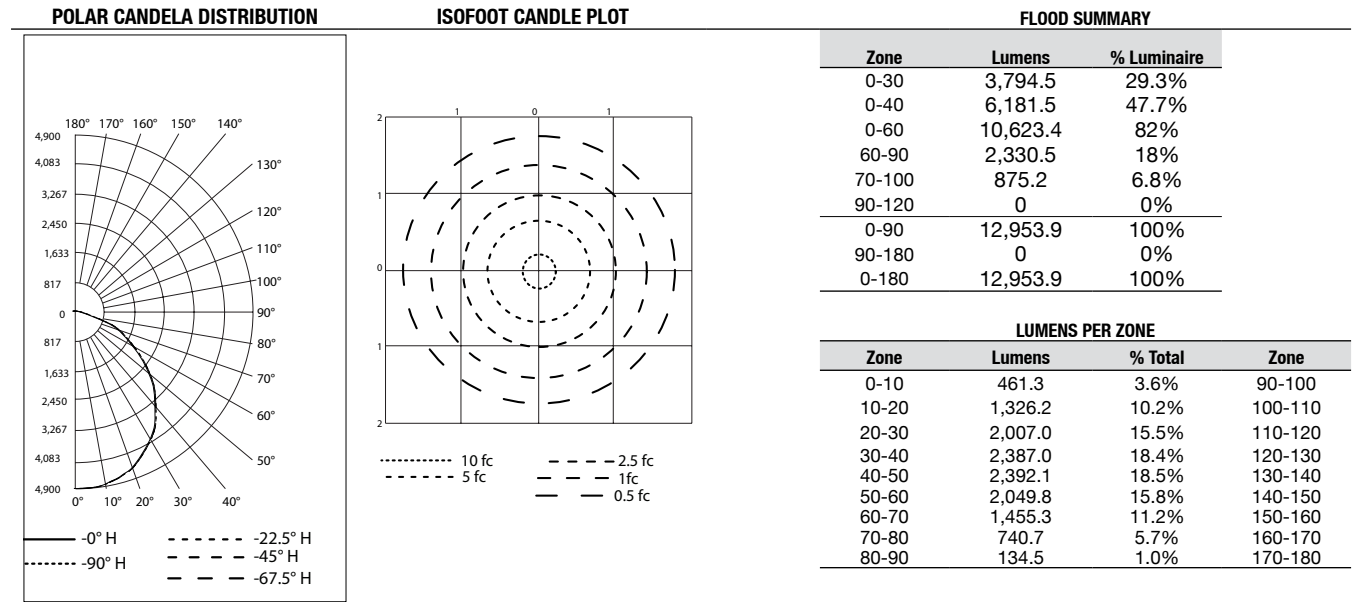

**Type V, Clear Glass**  
 REPORT NUMBER: **IBLLPL8CFMNB**

Luminaire Lumens 16,711

